

**SOPA6301TX**  
60CM CLASSIC PYRO OVEN

**MADE IN ITALY**  
Since 1948



**REFINED TRADITIONAL COOKING**

Whether you're a passionate cook, master baker or avid entertainer, this oven enables self-expression in the kitchen. Ten traditional cooking functions including static, fan forced, turbo, grill and more, provides endless cooking options at your fingertips. From creating wonderfully crisped pies, tarts and quiches, to perfectly cooked roasts and vegetables, you can rely on this oven to deliver optimised heating and oven conditions to cook various dishes without odour and flavour transfer.

**ULTIMATE CLEANING**

Pyrolytic self-cleaning oven technology means one less kitchen chore. The oven heats to a temperature approaching 500°C for up to three hours and carbonises grease and food residue to a fine ash that can be easily wiped out with a damp cloth. No harsh chemicals are required and the door remains safe to touch.

**EVERCLEAN ENAMEL**

The superior quality of Smeg's signature Ever Clean enamel, which is highly durable and easy to clean, is the result of over 70 years of enameling expertise; ensuring the exceptional long-life performance of every Smeg oven.



**TEN TRADITIONAL COOKING FUNCTIONS:**



**OTHER FUNCTIONS:**

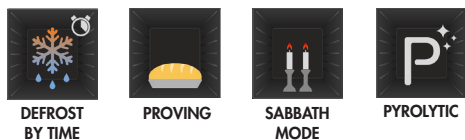

**ELECTRONIC TEMPERATURE CONTROL**

Precision is at the heart of Smeg's electronic temperature control. Offering 5 degree Celsius increments you can set the oven to the most suitable temperature with ease and precision.

## SOPA6301TX

### 60CM CLASSIC PYRO OVEN

MADE IN ITALY  
Since 1948

#### OVEN FEATURES

EAN	8017709314033
Dimensions	597mmW x 592mmH x 548mmD (excludes door and handle)
Finish	Stainless Steel Black eclipse glass
Cooking functions	10
Other functions	4
Display	Compact Screen
Gross volume	78L
Net volume	68L
Shelf positions	5
Thermostat	30° C - 280° C
Smart cooking	No
Cooking with probe	No
DeltaT cooking	No
SameTime	No
Multi-step cooking	No
Rapid pre-heat	Yes
Instant GO	No
Installation	Built-in
Cleaning	Pyrolytic
Lighting	2 x 40W Halogen
Safety	Cool door technology, thermal protection system, control lock
Timer	Delay start and automatic end cooking Minute minder
Door	Standard
Power	220-240V, 50/60Hz 3000W 13A Connection
Warranty	Two years parts and labour

#### TEN TRADITIONAL COOKING FUNCTIONS:



#### OTHER FUNCTIONS:



#### INCLUDED ACCESSORIES

- 1 x Chrome shelf
- 1 x Chrome grill insert
- 1 x ET20 - 20mm enamelled baking tray
- 1 x ET50 - 50mm enamelled baking tray
- 1 x Partial telescopic guides

#### OPTIONAL ACCESSORIES

- ET20 - 20mm enamelled baking tray
- ET50 - 50mm enamelled baking tray
- GTP2 - Partial telescopic guides
- GTT2 - Full telescopic guides
- STONE - Pizza stone

**SOPA6301TX**  
60CM CLASSIC PYRO OVEN

MADE IN ITALY  
Since 1948

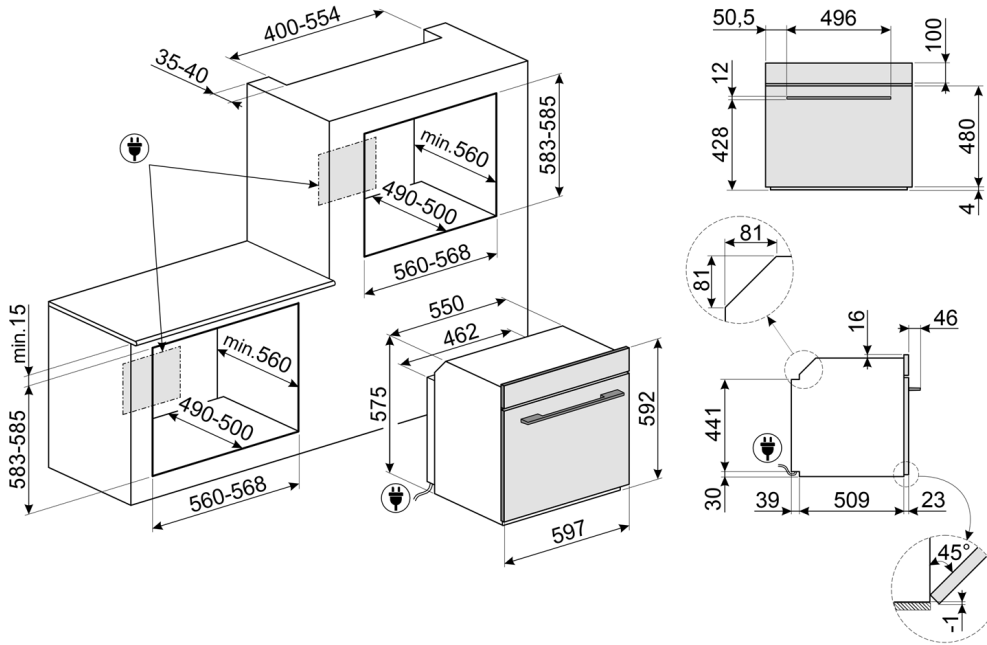

Dimensions	597mmW x 592mmH x 548mmD (excludes door and handle)
Power	220-240V, 50/60Hz 3000W 13A Connection

PLEASE NOTE: drawings are not to scale. They are to assist only.  
WARNING: technical specifications and product sizes can be varied by the manufacturer without notice.  
Cutouts for appliances should only be by physical product measurements. The above information is indicative only.