

## SOPA3104TPS

### 30" LINEA PYRO OVEN INC MULTI-POINT PROBE



#### THERMOSEAL

The seal of Smeg's quality, technical excellence and taste: succulent roasts, crisp pastry and impressive baking is achieved in Smeg's unique, perfectly controlled cooking environment. Thermoseal maintains the perfect atmospheric balance in the cavity for optimum cooking conditions.



#### EVER CLEAN ENAMEL

The superior quality of Smeg's patented Ever Clean enamel, which is highly durable and easy to clean, is the result of nearly 70 years of enameling expertise; ensuring long-life performance of every Smeg oven.



#### PYROLYTIC CLEANING

Smeg's pyrolytic cleaning cycle ingeniously uses heat to break down tough food residue and burnt-on grease to a small amount of ash. This can then be simply wiped away. It's the environmentally friendly way to clean your oven without the use of chemicals.



#### MULTI POINT PROBE

Take the guess work out of achieving the perfect roast. When guests arrive, ensure a juicy and tender roast is on the dinner table with this precision cooking tool.

EAN 8017709312084

Dimensions	754mmW x 710mmH x 582mmD (excluding handle)
Finish	Silver Stopsal glass
Total functions	10 cooking functions plus defrost by time, defrost by weight, plate rack/warm, keep warm, proving, sabbath, pyrolytic cleaning
Automatic Programmes	50
Display	VIVOScreen
Capacity	115L Gross/111L Net
Cooking levels	5
Thermostat	30 - 280°C
Cooking with Probe	Yes
Delat T	Yes
Sametime	Yes
Instant GO	Yes
Multi-step cooking	2 Steps
Installation	Built-in
Programmability	Fully programmable
Cleaning	Pyrolytic cleaning
Lighting	2 x 40W halogen
Supplied accessories	2 x chrome shelves 1 x 40mm enamelled baking tray 1 x Total telescopic guides 1 x Multipoint probe
Safety	Cool Door technology, thermal protection system, control lock and child safety lock
Power	220-240V, 50Hz 4,000W 18A Connection
Warranty	Five years parts and labour

ID230615

**SOPA3104TPS**  
30" LINEA PYRO OVEN INC MULTI-POINT PROBE

FUNCTIONS

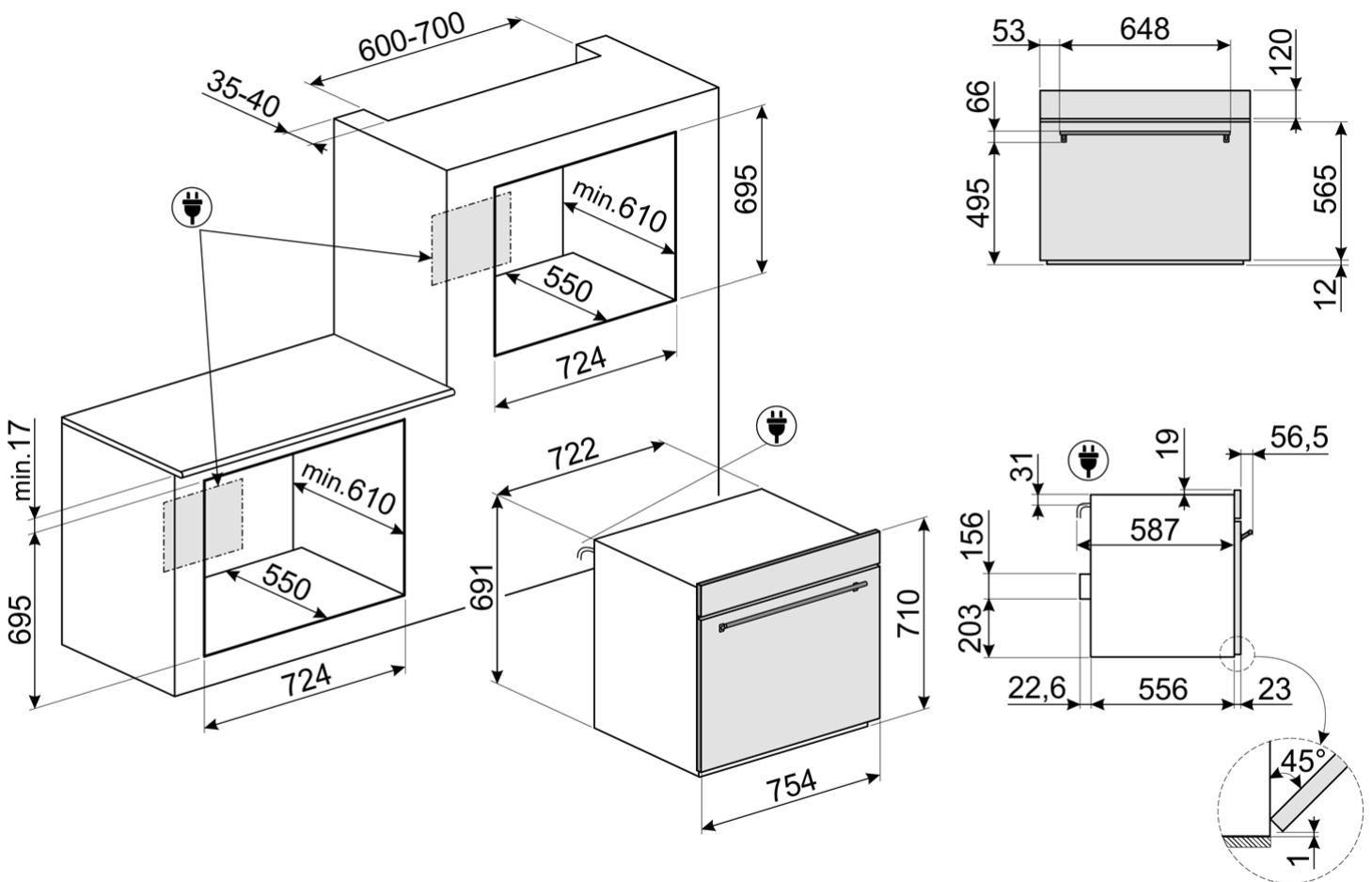
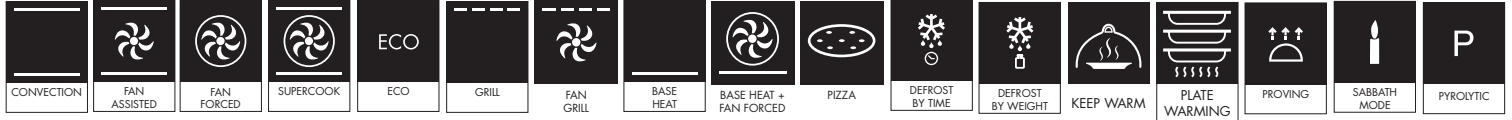

PLEASE NOTE: drawings are not to scale. They are to assist only.  
WARNING: technical specifications and product sizes can be varied by the manufacturer without notice.  
Cutouts for appliances should only be by physical product measurements. The above information is indicative only.