

SHU750X

70CM UNDERMOUNT RANGEHOOD



EAN 8017709309046

- Finish Stainless steel
- Dimensions 700mmW x 221mmH x 286mmD
- Installation Undermount
- Motor 1 x 144W
- Air extraction • Duct direct to atmosphere or recirculate
- Capacity 400m³/hr (IEC 61591)
- Noise rating 54–70 dBA (IEC 60704-2-13)
- Illumination 2 x LED
- Speeds Three
- Power supply 220–240V, 50Hz
- Supplied 2 x Aluminium grease filters
- Optional Charcoal filter KITFC6191
(Spare Part Number 112.0567.664)

	Extraction rate IEC 61591 [m ³ /h]	Noise level IEC 60704-2-13 [dB(A)]
Speed 1	185	54
Speed 2	275	62
Speed 3	400	70

SHU750X
70CM UNDERMOUNT RANGEHOOD

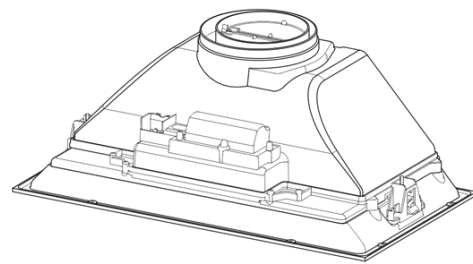
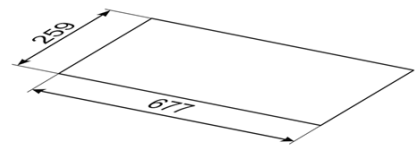
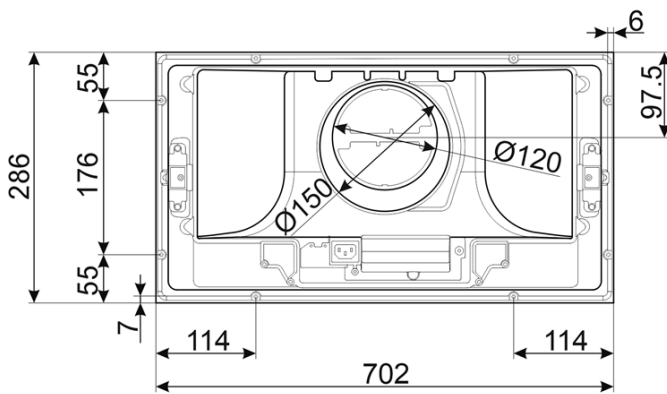
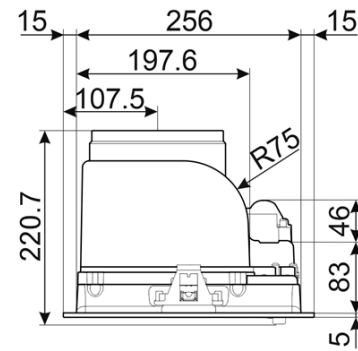
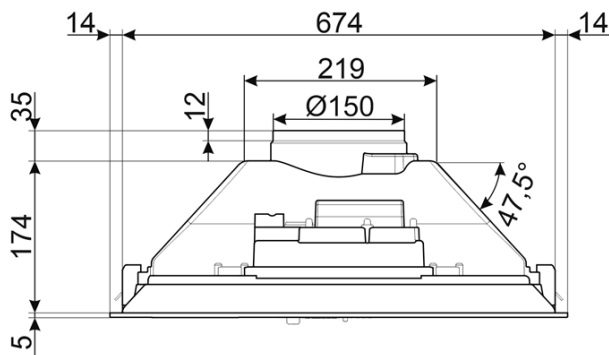

WARNING: technical specifications and product sizes can be varied by the manufacturer without notice. Cutouts for appliances should only be by physical product measurements. The above information is indicative only.