

SOPA3302TPX

76CM CLASSIC PYRO OVEN



THERMOSEAL

The seal of Smeg's quality, technical excellence and taste: succulent roasts, crispy pastry and impressive baking is achieved in Smeg's unique, perfectly controlled cooking environment. ThermoSeal maintains the perfect atmospheric balance in the cavity for optimum cooking conditions.



EVER CLEAN ENAMEL

The superior quality of Smeg's patented Ever Clean enamel, which is highly durable and easy to clean, is the result of over 75 years of enamelling expertise; ensuring long-life performance of every Smeg oven.

PYROLYTIC CLEANING

Smeg's pyrolytic cleaning cycle ingeniously uses heat to break down tough food residue and burnt-on grease to a small amount of ash. This can then be simply wiped away. It's the environmentally friendly way to clean your oven without the use of chemicals.



TEN TRADITIONAL COOKING FUNCTIONS:



OTHER FUNCTIONS:

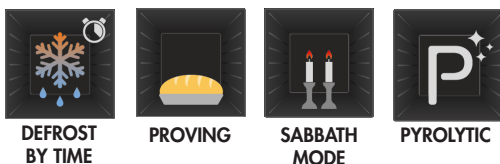

SINGLE-POINT PROBE

Take the guess work out of achieving the perfect roast. When guests arrive, ensure a juicy and tender roast is on the dinner table with this precision cooking tool.

CLASSIC DESIGN

Reimagining Smeg's most enduring collection to date - embodying signature Italian style and industry leading innovation. The range is distinctive for the way it uses stainless steel with the utmost stylistic rigour. Classic highlights the unique control knobs and the clean, refined and ergonomic handles that combines elements of industrial design.

SOPA3302TPX

76CM CLASSIC PYRO OVEN

OVEN FEATURES

EAN	8017709311131
Dimensions	754mmW x 710mmH x 587mmD (excludes door and handle)
Finish	Stainless Steel Eclipse high visibility black glass
Cooking functions	10
Other functions	4
Display	EvoScreen
Gross volume	117L
Net volume	111L
Shelf positions	6
Thermostat	30° C - 280° C
Smart cooking	No
Cooking with probe	Yes
DeltaT cooking	No
SameTime	No
Multi-step cooking	No
Rapid pre-heat	Yes
Instant GO	Yes
Installation	Built-in
Cleaning	Pyrolytic
Lighting	2 x Halogen
Safety	Thermal protection system, control lock, cool door technology
Timer	Delay start and automatic end cooking Minute minder
Door	Standard
Power	220-240V, 50/60Hz 4000W 18A Connection
Warranty	Two years parts and labour

OVEN FUNCTIONS

TEN TRADITIONAL COOKING FUNCTIONS:



OTHER FUNCTIONS:

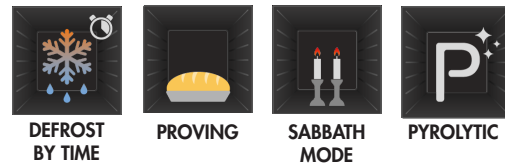

INCLUDED ACCESSORIES

- 2 x Chrome shelves
- 1 x 40mm enamelled baking tray
- 1 x Single-point temperature probe
- 1 x Full telescopic guides

SOPA3302TPX

76CM CLASSIC PYRO OVEN

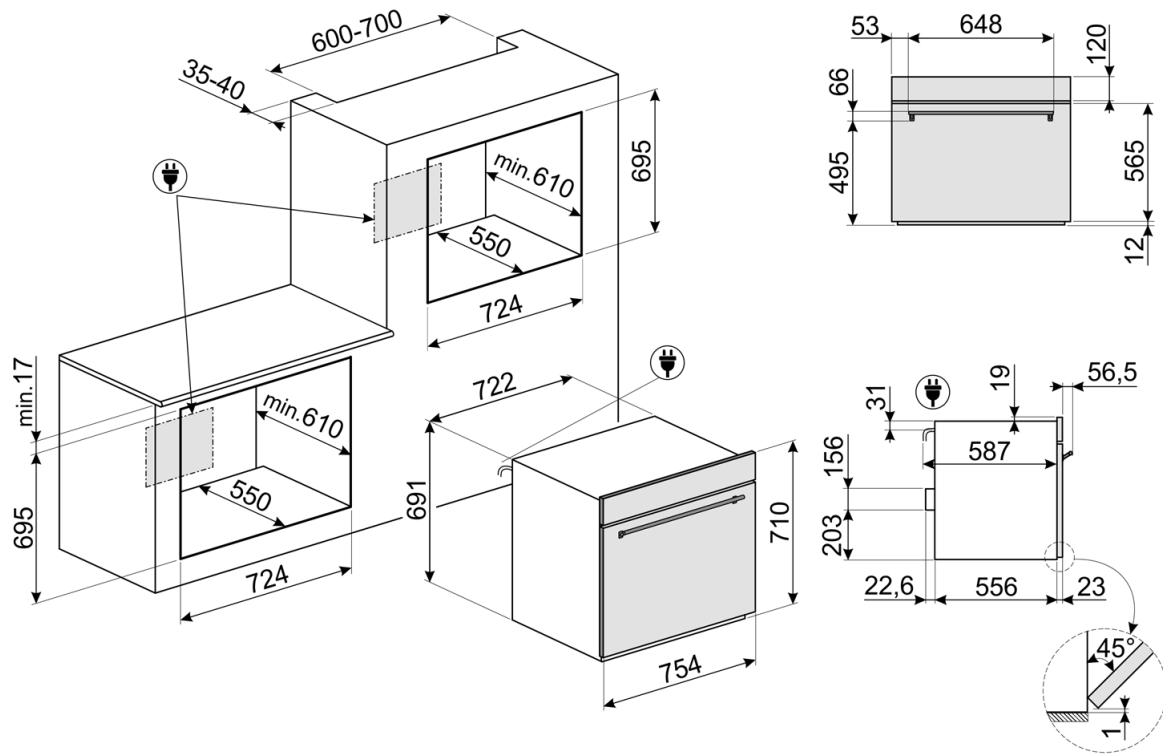

Dimensions	754mmW x 710mmH x 587mmD (excludes door and handle)
Power	220-240V, 50/60Hz 4000W 18A Connection

PLEASE NOTE: drawings are not to scale. They are to assist only.
WARNING: technical specifications and product sizes can be varied by the manufacturer without notice.
Cutouts for appliances should only be by physical product measurements. The above information is indicative only.